

SkyLine PremiumS Electric Combi Oven 20GN1/1, Green Version

ITEM # _____

MODEL # _____

NAME # _____

SIS # _____

AIA # _____

229714 (ECO20IT3C0)

SkyLine PremiumS Combi Boiler Oven with touch screen control, 20x1/1GN, electric, 3 cooking modes (automatic, recipe program, manual), automatic cleaning, Green Version with 3-glass door

229724 (ECO20IT3A0)

SkyLine PremiumS Combi Boiler Oven with touch screen control, 20x1/1GN, electric, 3 cooking modes (automatic, recipe program, manual), automatic cleaning, Green Version with 3-glass door

Short Form Specification

Item No. _____

Combi oven with high resolution full touch screen interface, multilanguage

- Built-in steam generator with real humidity control based upon Lambda Sensor
- OptiFlow air distribution system to achieve maximum performance with 7 fan speed levels
- SkyClean: Automatic and built-in self cleaning system with integrated descale of the steam generator. 5 automatic cycles (soft, medium, strong, extra strong, rinse-only) and green functions to save energy, water, detergent and rinse aid
- Cooking modes: Automatic (9 food families with 100+ different pre-installed variants); Programs (a maximum of 1000 recipes can be stored and organized in 16 different categories); Manual (steam, combi and convection cycles); Specialistic Cycles (regeneration, Low Temperature Cooking, proving, EcoDelta, Sous-Vide, Static-Combi, Pasteurization of pasta, dehydration, Food Safe Control and Advanced Food Safe Control)
- Special functions: MultiTimer cooking, Plan-n-Save to cut running costs, Make-it-Mine to customize interface, SkyHub to customize homepage, agenda MyPlanner, SkyDuo connection to SkyLine Chillers, automatic backup mode to avoid downtime
- USB port to download HACCP data, programs and settings. Connectivity ready
- 6-point multi sensor core temperature probe
- Triple-glass door with double LED lights line
- Stainless steel construction throughout
- Supplied with n.1 trolley rack 1/1 GN, 63 mm pitch.
- Adjustable levelling feet.

Main Features

- High resolution full touch screen interface (translated in more than 30 languages) - color-blind friendly panel.
- Built-in steam generator for highly precise humidity and temperature control according to the chosen settings.
- Real humidity control based upon Lambda Sensor to automatically recognize quantity and size of food for consistent quality results.
- Dry, hot convection cycle (25 °C - 300 °C): ideal for low humidity cooking.
- Combination cycle (25 °C - 300 °C): combining convected heat and steam to obtain humidity controlled cooking environment, accelerating the cooking process and reducing weight loss.
- Low temperature Steam cycle (25 °C - 99 °C): ideal for sous-vide, re-thermalization and delicate cooking.
Steam cycle (100 °C): seafood and vegetables.
High temperature steam (25 °C - 130 °C).
- Automatic mode including 9 food families (meat, poultry, fish, vegetables, pasta/rice, eggs, savory and sweet bakery, bread, dessert) with 100+ different pre-installed variants. Through Automatic Sensing Phase the oven optimizes the cooking process according to size, quantity and type of food loaded to achieve the selected cooking result. Real time overview of the cooking parameters. Possibility to personalize and save up to 70 variants per family.
- Cycles+:
 - Regeneration (ideal for banqueting on plate or rethermalizing on tray),
 - Low Temperature Cooking (to minimize weight loss and maximize food quality) Patented US7750272B2 and related family,
 - Proving cycle,
 - EcoDelta cooking, cooking with food probe maintaining preset temperature difference between the core of the food and the cooking chamber,
 - Sous-vide cooking,
 - Static Combi (to reproduce traditional cooking from static oven),
 - Pasteurization of pasta,
 - Dehydration cycles (ideal for drying fruits, vegetables, meats, seafood),
 - Food Safe Control (to automatically monitor safety of cooking process in compliance with HACCP hygienic standards) Patented US6818865B2 and related family,
 - Advanced Food Safe Control (to drive the cooking with pasteurization factor).
- Programs mode: a maximum of 1000 recipes can be stored in the oven's memory, to recreate the exact same recipe at any time. The recipes can be group in 16 different categories to better organize the menu. 16-step cooking programs also available.
- MultiTimer function to manage up to 20 different cooking cycles at the same time, improving flexibility and ensuring excellent cooking results. Can be saved up to 200 MultiTimer programs.
- OptiFlow air distribution system to achieve maximum performance in cooking evenness and temperature control thanks to a special design of the cooking chamber combined with high precision

APPROVAL: _____

variable speed fan and venting valve.

- Fan with 7 speed levels from 300 to 1500 RPM and reverse rotation for optimal evenness. Fan stops in less than 5 seconds when door is opened.
- 6-point multi sensor core temperature probe for maximum precision and food safety.
- Pictures upload for full customization of cooking cycles.
- Automatic fast cool down and pre-heat function.
- Reduced powerfunction for customized slow cooking cycles.
- SkyClean: Automatic and built-in self cleaning system with integrated descale of the steam generator. 5 automatic cycles (soft, medium, strong, extra strong, rinse-only) and green functions to save energy, water, detergent and rinse aid. Also programmable with delayed start.
- Different chemical options available: solid (phosphate-free), liquid (requires optional accessory).
- Plan-n-Save function organizes the cooking sequence of the chosen cycles optimizing the work in the kitchen from a time and energy efficiency point of view.
- Make-it-mine feature to allow full personalization or locking of the user interface.
- SkyHub lets the user group the favorite functions in the homepage for immediate access.
- MyPlanner works as an agenda where the user can plan the daily work and receive personalized alerts for each task.
- With SkyDuo the Oven and the Blast Chiller are connected to each other and communicate in order to guide the user through the cook&chill process optimizing time and efficiency (requires optional accessory).
- GreaseOut: predisposed for integrated grease drain and collection for safer operation (dedicated base as optional accessory).
- USB port to download HACCP data, share cooking programs and configurations. USB port also allows to plug-in sous-vide probe (optional accessory).
- Connectivity ready for real time access to connected appliances from remote and HACCP monitoring (requires optional accessory).
- Trainings and guidances supporting materials easily accessible by scanning QR-Code with any mobile device.
- Back-up mode with self-diagnosis is automatically activated if a failure occurs to avoid downtime.
- Automatic consumption visualization at the end of the cycle.
- Capacity: 20 GN 1/1 trays.
- Connectivity ready for real time access to connected appliances from remote and data monitoring (requires optional accessory - contact the Company for more details).

Construction

- Human centered design with 4-star certification for ergonomics and usability.
- Wing-shaped handle with ergonomic design and hands-free opening with the elbow, making managing trays simpler. Protected by registered design (EM003143551 and related family).
- Triple thermo-glazed door with 2 hinged inside panels for easy cleaning and double LED lights line.
- Seamless hygienic internal chamber with all rounded corners for easy cleaning.
- 304 AISI stainless steel construction throughout.
- Front access to control board for easy service.
- Integrated spray gun with automatic retracting system for fast rinsing.
- Supplied with n.1 tray rack 1/1GN, 63 mm pitch.

- IPX 5 spray water protection certification for easy cleaning.
- Integrated door shield to avoid steam and heat dispersion from the door, when the roll-in rack is not used.

Included Accessories

- 1 of Trolley with tray rack, 20 GN 1/1, 63mm pitch PNC 922753

Optional Accessories

- | | | |
|---|------------|--------------------------|
| • Water softener with cartridge and flow meter (high steam usage) | PNC 920003 | <input type="checkbox"/> |
| • Water filter with cartridge and flow meter for 6 & 10 GN 1/1 ovens (low-medium steam usage - less than 2hrs per day full steam) | PNC 920004 | <input type="checkbox"/> |
| • Water softener with salt for ovens with automatic regeneration of resin | PNC 921305 | <input type="checkbox"/> |
| • Pair of AISI 304 stainless steel grids, GN 1/1 | PNC 922017 | <input type="checkbox"/> |
| • Pair of grids for whole chicken (8 per grid - 1,2kg each), GN 1/1 | PNC 922036 | <input type="checkbox"/> |
| • AISI 304 stainless steel grid, GN 1/1 | PNC 922062 | <input type="checkbox"/> |
| • Grid for whole chicken (4 per grid - 1,2kg each), GN 1/2 | PNC 922086 | <input type="checkbox"/> |
| • External side spray unit (needs to be mounted outside and includes support to be mounted on the oven) | PNC 922171 | <input type="checkbox"/> |
| • Baking tray for 5 baguettes in perforated aluminum with silicon coating, 400x600x38mm | PNC 922189 | <input type="checkbox"/> |
| • Baking tray with 4 edges in perforated aluminum, 400x600x20mm | PNC 922190 | <input type="checkbox"/> |
| • Baking tray with 4 edges in aluminum, 400x600x20mm | PNC 922191 | <input type="checkbox"/> |
| • Pair of frying baskets | PNC 922239 | <input type="checkbox"/> |
| • AISI 304 stainless steel bakery/pastry grid 400x600mm | PNC 922264 | <input type="checkbox"/> |
| • Grid for whole chicken (8 per grid - 1,2kg each), GN 1/1 | PNC 922266 | <input type="checkbox"/> |
| • USB probe for sous-vide cooking | PNC 922281 | <input type="checkbox"/> |
| • Grease collection tray, GN 1/1, H=100 mm | PNC 922321 | <input type="checkbox"/> |
| • Kit universal skewer rack and 4 long skewers for Lengthwise ovens | PNC 922324 | <input type="checkbox"/> |
| • Universal skewer rack | PNC 922326 | <input type="checkbox"/> |
| • 4 long skewers | PNC 922327 | <input type="checkbox"/> |
| • Volcano Smoker for lengthwise and crosswise oven | PNC 922338 | <input type="checkbox"/> |
| • Multipurpose hook | PNC 922348 | <input type="checkbox"/> |
| • Grid for whole duck (8 per grid - 1,8kg each), GN 1/1 | PNC 922362 | <input type="checkbox"/> |
| • Thermal cover for 20 GN 1/1 oven and blast chiller freezer | PNC 922365 | <input type="checkbox"/> |
| • Wall mounted detergent tank holder | PNC 922386 | <input type="checkbox"/> |
| • USB single point probe | PNC 922390 | <input type="checkbox"/> |
| • Connectivity hub (SIM) Router Ethernet + WiFi + 4G (UE) | PNC 922399 | <input type="checkbox"/> |
| • Connectivity hub (LAN) Router Ethernet + WiFi | PNC 922412 | <input type="checkbox"/> |
| • External connection kit for liquid detergent and rinse aid | PNC 922618 | <input type="checkbox"/> |
| • Dehydration tray, GN 1/1, H=20mm | PNC 922651 | <input type="checkbox"/> |
| • Flat dehydration tray, GN 1/1 | PNC 922652 | <input type="checkbox"/> |



• Heat shield for 20 GN 1/1 oven	PNC 922659	<input type="checkbox"/>	• Non-stick universal pan, GN 1/2, H=20mm	PNC 925009	<input type="checkbox"/>
• Trolley with tray rack, 15 GN 1/1, 84mm pitch	PNC 922683	<input type="checkbox"/>	• Non-stick universal pan, GN 1/2, H=40mm	PNC 925010	<input type="checkbox"/>
• Kit to fix oven to the wall	PNC 922687	<input type="checkbox"/>	• Non-stick universal pan, GN 1/2, H=60mm	PNC 925011	<input type="checkbox"/>
• Connectivity WiFi board (NIU-HACL) for SkyLine/Magistar and Rapido	PNC 922695	<input type="checkbox"/>			
• Ethernet board (NIU-LAN) for Ovens and green&clean Rack Type Dishwashers	PNC 922696	<input type="checkbox"/>			
• 4 flanged feet for 20 GN , 2", 100-130mm	PNC 922707	<input type="checkbox"/>			
• Mesh grilling grid, GN 1/1	PNC 922713	<input type="checkbox"/>			
• Probe holder for liquids	PNC 922714	<input type="checkbox"/>			
• Odour reduction hood with fan for 20 GN 1/1 electric oven	PNC 922720	<input type="checkbox"/>			
• Condensation hood with fan for 20 GN 1/1 electric oven	PNC 922725	<input type="checkbox"/>			
• Exhaust hood with fan for 20 GN 1/1 oven	PNC 922730	<input type="checkbox"/>			
• Exhaust hood without fan for 20 1/1GN oven	PNC 922735	<input type="checkbox"/>			
• Holder for trolley handle (when trolley is in the oven) for 20 GN oven	PNC 922743	<input type="checkbox"/>			
• Tray for traditional static cooking, H=100mm	PNC 922746	<input type="checkbox"/>			
• Double-face griddle, one side ribbed and one side smooth, 400x600mm	PNC 922747	<input type="checkbox"/>			
• Trolley with tray rack, 20 GN 1/1, 63mm pitch	PNC 922753	<input type="checkbox"/>			
• Trolley with tray rack, 16 GN 1/1, 80mm pitch	PNC 922754	<input type="checkbox"/>			
• Banquet trolley with rack holding 54 plates for 20 GN 1/1 oven and blast chiller freezer, 74mm pitch	PNC 922756	<input type="checkbox"/>			
• Bakery/pastry trolley with rack holding 600x400mm grids for 20 GN 1/1 oven and blast chiller freezer, 80mm pitch (16 runners)	PNC 922761	<input type="checkbox"/>			
• Banquet trolley with rack holding 45 plates for 20 GN 1/1 oven and blast chiller freezer, 90mm pitch	PNC 922763	<input type="checkbox"/>			
• Kit compatibility for aos/easyline trolley (produced till 2019) with SkyLine/Magistar 20 GN 1/1 combi oven	PNC 922769	<input type="checkbox"/>			
• Kit compatibility for aos/easyline 20 GN oven with SkyLine/Magistar trolleys	PNC 922771	<input type="checkbox"/>			
• Water inlet pressure reducer	PNC 922773	<input type="checkbox"/>			
• Extension for condensation tube, 37cm	PNC 922776	<input type="checkbox"/>			
• Kit for installation of electric power peak management system for 20 GN Oven	PNC 922778	<input type="checkbox"/>			
• Non-stick universal pan, GN 1/1, H=40mm	PNC 925001	<input type="checkbox"/>			
• Non-stick universal pan, GN 1/1, H=60mm	PNC 925002	<input type="checkbox"/>			
• Double-face griddle, one side ribbed and one side smooth, GN 1/1	PNC 925003	<input type="checkbox"/>			
• Aluminum grill, GN 1/1	PNC 925004	<input type="checkbox"/>			
• Frying pan for 8 eggs, pancakes, hamburgers, GN 1/1	PNC 925005	<input type="checkbox"/>			
• Flat baking tray with 2 edges, GN 1/1	PNC 925006	<input type="checkbox"/>			
• Baking tray for 4 baguettes, GN 1/1	PNC 925007	<input type="checkbox"/>			
• Potato baker for 28 potatoes, GN 1/1	PNC 925008	<input type="checkbox"/>			

Electric
Supply voltage:

229714 (ECO201T3C0)	220-240 V/3 ph/50-60 Hz
229724 (ECO201T3A0)	380-415 V/3N ph/50-60 Hz

Electrical power, default: 37.7 kW

Default power corresponds to factory test conditions. When supply voltage is declared as a range the test is performed at the average value. According to the country, the installed power may vary within the range.

Electrical power max.: 40.4 kW

Circuit breaker required
Water:
Water inlet connections "CW11-CW12": 3/4"

Pressure, bar min/max: 1-6 bar

Drain "D": 50mm

Max inlet water supply temperature: 30 °C

Chlorides: <17 ppm

Conductivity: >50 µS/cm

Electrolux Professional recommends the use of treated water, based on testing of specific water conditions.

Please refer to user manual for detailed water quality information.

Installation:
Clearance: Clearance: 5 cm rear and right hand sides.

Suggested clearance for service access: 50 cm left hand side.

Capacity:
Trays type: 20 - 1/1 Gastronorm

Max load capacity: 100 kg

Key Information:
Door hinges:
External dimensions, Width: 911 mm

External dimensions, Depth: 864 mm

External dimensions, Height: 1794 mm

Net weight: 280 kg

Shipping weight:
229714 (ECO201T3C0) 313 kg

229724 (ECO201T3A0) 310 kg

Shipping volume: 1.83 m³

Front

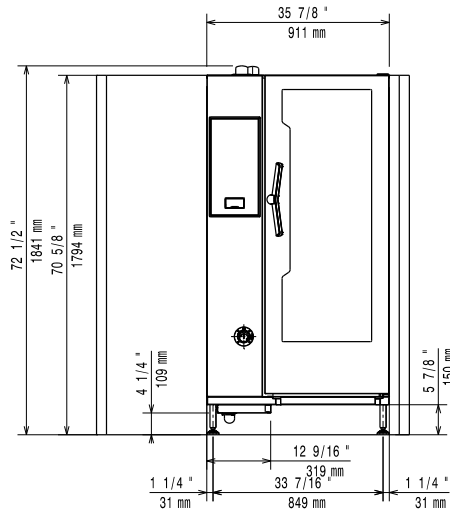

Distances

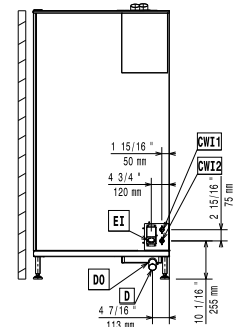

- CWI1 = Cold Water inlet 1 (cleaning)
- CWI2 = Cold Water Inlet 2 (steam generator)
- D = Drain
- DO = Overflow drain pipe
- EI = Electrical inlet (power)

Side

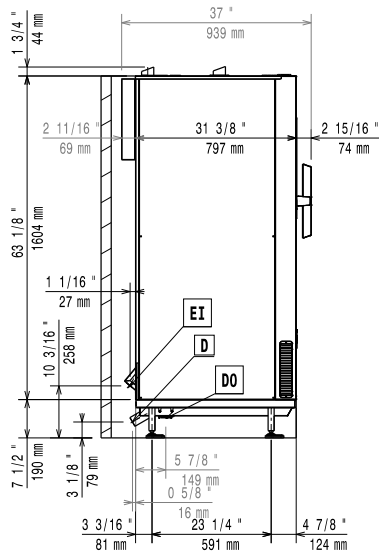

- CWI1 = Cold Water inlet 1 (cleaning)
- CWI2 = Cold Water Inlet 2 (steam generator)
- D = Drain
- DO = Overflow drain pipe
- EI = Electrical inlet (power)

Top

